



BALI



GIAVA

Specifiche tecniche:

Codice:	IPN67R	IPN67Q
Forma:	Rotonda	Quadrata
Voltaggio:	220-240V	
Grado IP:	IP67	
Grado IK:	08	
Attacco:	GU10	
Classe:	I	
Temp. ambientale:	-25°C +50°C	
Carrabile:	Sì	
Aisi:	201	
Carico Massimo:	<1000Kg	
Dimensioni:	110x110mm (100mm foro)	100x100mm (100mm foro)

Corpo in acciaio inox con finitura cromato lucido. Disponibile in due forme: rotonda e quadrata.

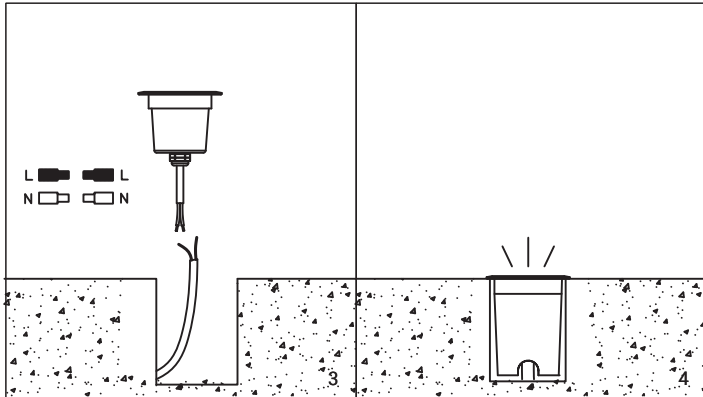

⚠ ATTENZIONE

Si prega di leggere attentamente il manuale utente prima di installare o utilizzare il prodotto.

Si raccomanda di non toccare il prodotto quando è acceso.

In caso di malfunzionamento, staccare la lampada dall'alimentazione.

Si raccomanda di rivolgersi a un elettricista e di non provare a riparare la lampada da soli.

MONTAGGIO:

1. Spegner l'alimentazione.
2. Rimuovere l'anello anteriore della lampada.
3. Montare la lampada.
4. Collegare l'alimentazione secondo il disegno.
5. Accendere la corrente solo dopo aver ultimato l'installazione.

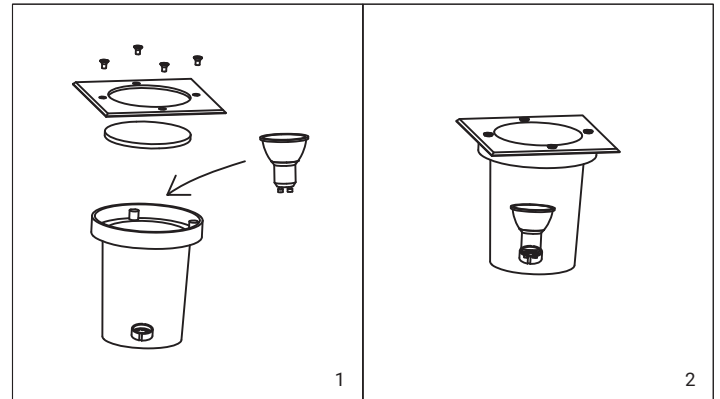

1

2

Informazioni sul riciclaggio in conformità con le direttive RAAE e batterie



Simbolo sul prodotto



Simbolo sulla batteria

Solo Europa

Il prodotto/batteria è contrassegnato con uno dei simboli di riciclaggio sopra indicati. Questo indica che a fine vita il prodotto/batteria, dovrà essere smaltito/a separatamente in appropriati luoghi di raccolta e non con i normali rifiuti domestici.

CE RoHs



IPERLUX®
www.iperlux.com
info@iperlux.com



IPERLUX®

INSTRUCTION MANUAL DRIVEWAY GU10 LAMP HOLDER IP67



BALI



GIAVA

Specifications and Technical Data sheet:

Code:	IPN67R	IPN67Q
Shape:	Round	Square
Voltage:	220-240V	
IP Grade:	IP67	
IK Grade:	08	
Bulb:	GU10	
Class:	I	
Amb.temp:	-25°C +50°C	
Driveway:	Yes	
Aisi:	201	
Max weight:	<1000Kg	
Size:	110x110mm (100mm hole)	100x100mm (100mm hole)

Stainless steel housing with polished chrome finish. Available in two shapes: round and square.

1

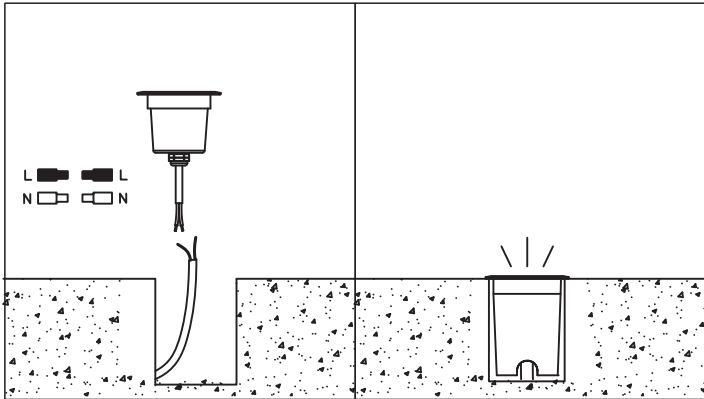

⚠ WARNING

It is recommended to contact a qualified electrician to install the product.

It is recommended not to touch the product when it is turned on.

In case of malfunction, disconnect the lamp from the power supply. It is recommended to contact an electrician and not try to repair the lamp yourself.

MOUNTING:

1. Switch off the power.
2. Remove the front ring of the items.
3. Mount the bulb.
4. Connect the cables following the images.
5. Switch on the power only after finishing the installation.

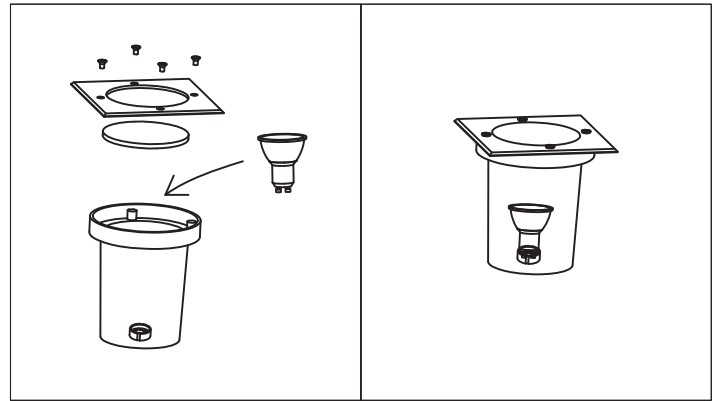

2

Recycling Information in Accordance with the WEEE and Battery Directives



Product Mark



Battery Mark

The product/battery is marked with one of the above recycling symbols. It indicates that at the end of the life of the product/battery, you should dispose of it separately at an appropriate collection point and not place it in normal domestic waste stream.



IPERLUX®
www.iperlux.com
info@iperlux.com

3